

STEP 1

PREPARE THE POWERMAX POWER TRUCK
(THE POWERMAX POWER TRUCK IS NOT INCLUDED IN THE KIT)

THE CENTER PIVOT MOUNTING BRACKET IS INCLUDED IN THE KIT WITH PERMISSION FROM SEARAILS. IT WILL NEED TO BE PREPARED IN THE STEPS SHOWN BELOW.

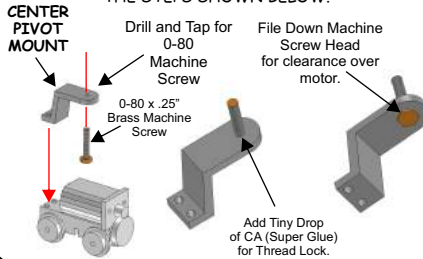

PLEASE NOTE!! MODIFYING YOUR POWERMAX! THIS WAY WILL VOID YOUR WARRANTY. THIS STEP IS FOR VISUAL AESTHETIC ONLY. THE LOCOMOTIVE WILL OPERATE WITHOUT PERFORMING THIS MODIFICATION.

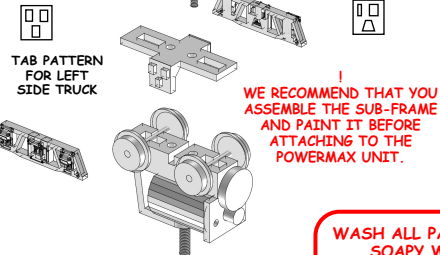
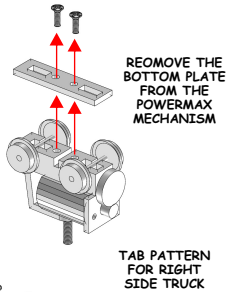

WASH ALL PARTS IN A SOAPY WATER SOLUTION OR ALCOHOL TO REMOVE ANY RESIDUE FROM THE PRODUCTION PROCESS.

ASSEMBLE THE FRAME

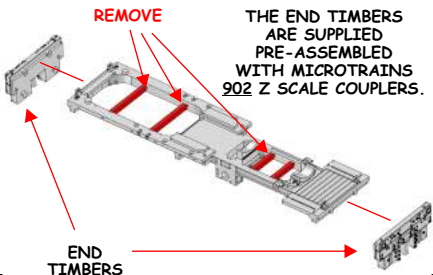

STEP 2

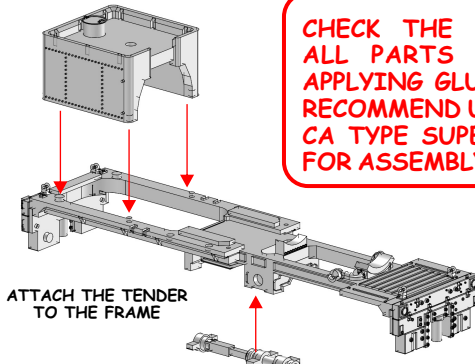

APPLY CA GLUE ON THE INSIDE OF THE JOINT AREA BETWEEN THE TENDER AND THE FRAME TO INCREASE THE STRENGTH OF THE JOINT AREA.

CHECK THE FIT OF ALL PARTS BEFORE APPLYING GLUE. WE RECOMMEND USING A CA TYPE SUPER GLUE FOR ASSEMBLY.

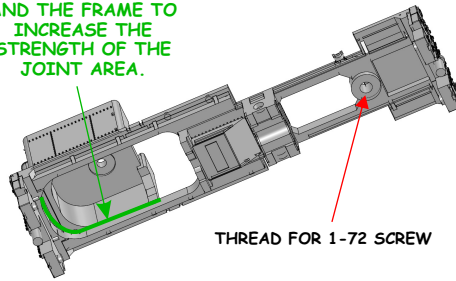

STEP 3

ASSEMBLE THE BOILER AND ATTACH TO THE FRAME

THE SMOKEBOX FRONT IS GROOVED TO ALLOW INSTALLATION OF LED (NOT INCLUDED) IN THE HEADLIGHT

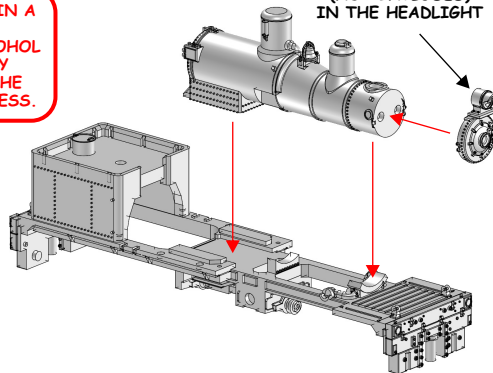

STEP 4

ATTACH THE SIDE FRAMES

IT MAY BE NECESSARY TO REMOVE THE TAB ON THE BACK OF THE SIDE FRAMES TO ALLOW IT TO FIT TO THE CAB

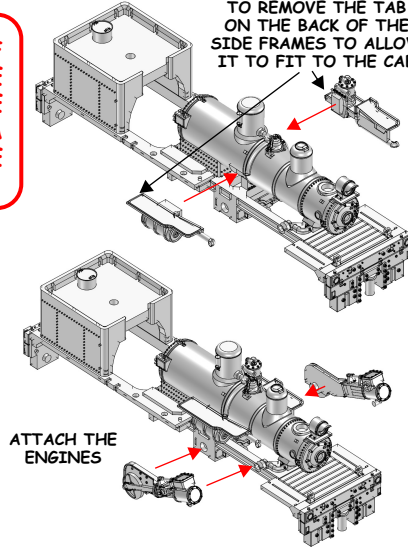

STEP 5

ADD YOUR CHOICE OF SMOKE STACKS

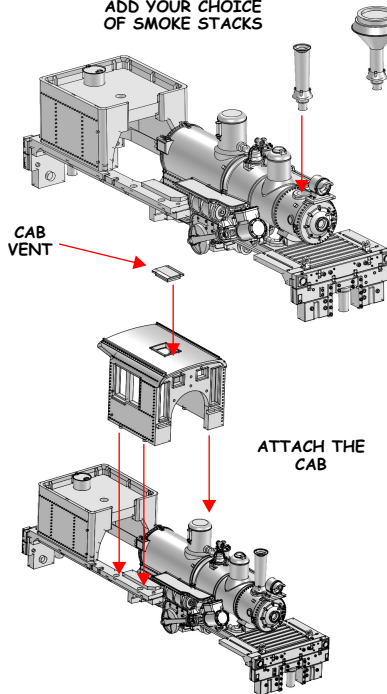

STEP 6

PILOT ASSEMBLY

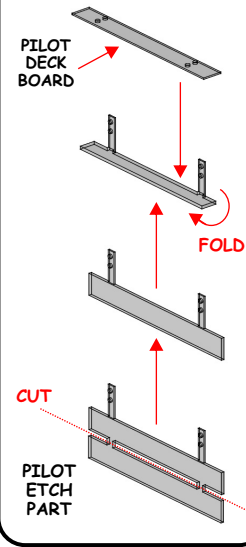

YOU CAN CHOOSE TO USE THE ETCHED DECK BOARDS OR THE INCLUDED FIBER DECK BOARDS. (SEE RIGHT)

STEP ASSEMBLY

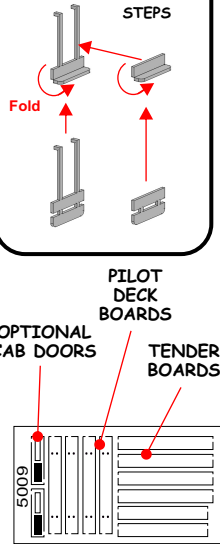

PAINING

TESTOR'S FLAT BLACK SPRAY PAINT IS A GOOD CHOICE. THIS PAINT IS VERY THIN, COVERS WELL AND IS DURABLE. WE RECOMMEND THAT YOU USE A METAL PRIMER FIRST AND RECOMMEND TAMIYA BRAND LAQUER SURFACE PRIMER.

WE RECOMMEND USING A PHOTO-ETCH BENDING TOOL FOR ASSEMBLY

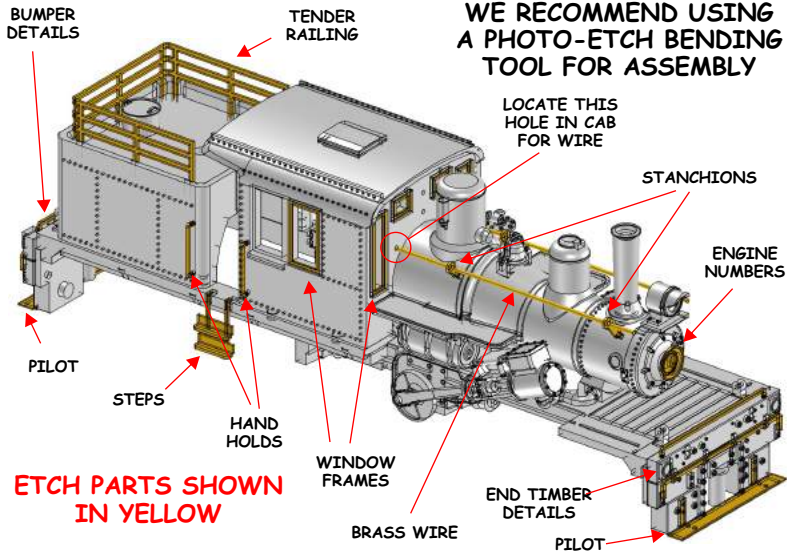

STEP 7
PHOTO-ETCH DETAILS

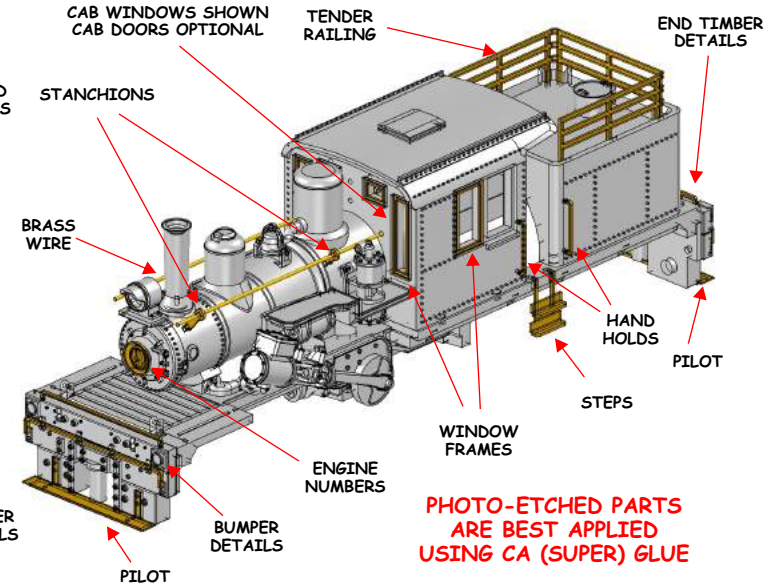
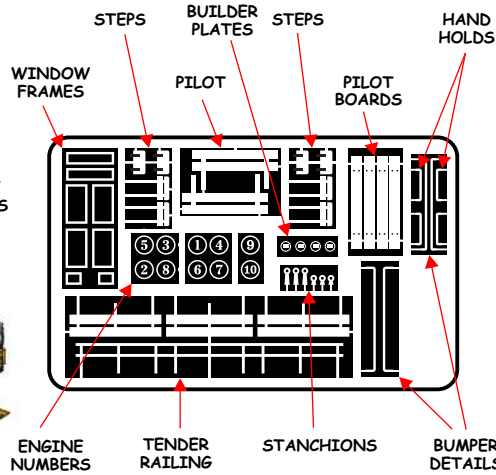

PARTS LIST

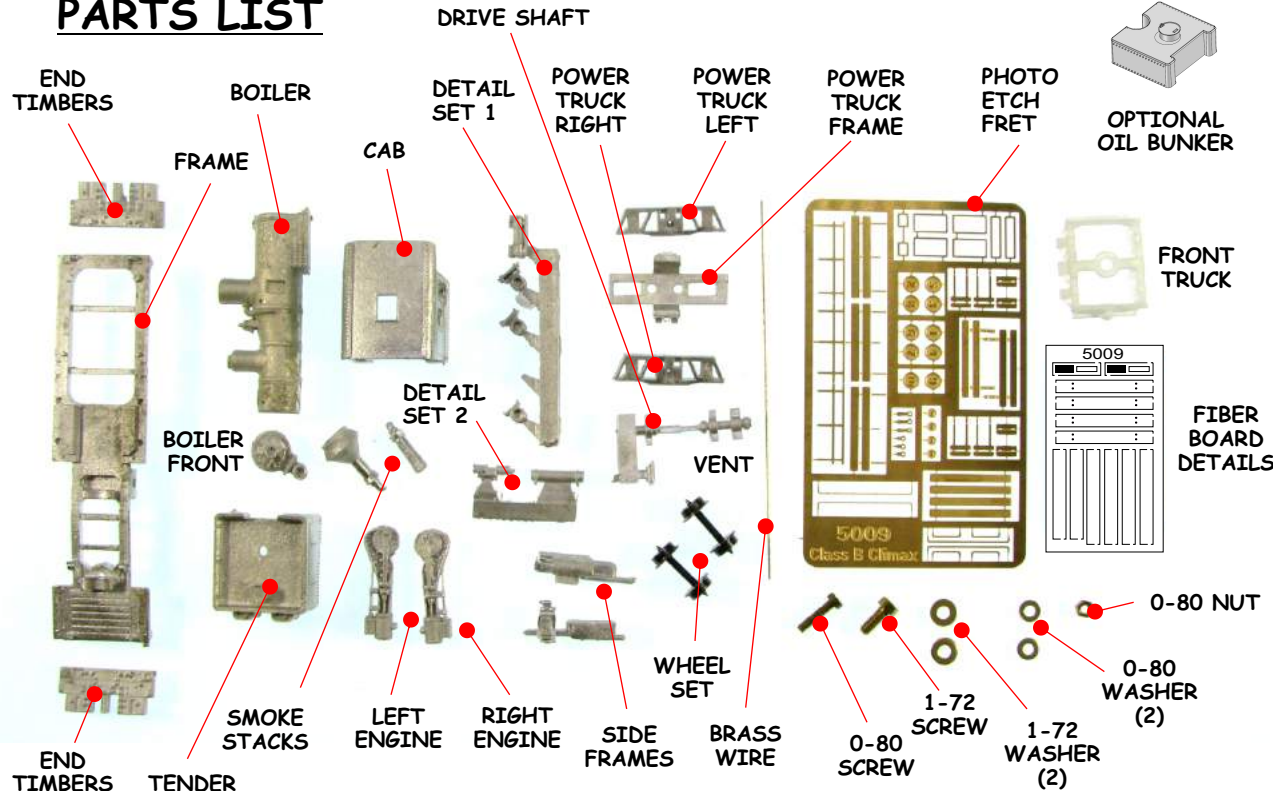

INSTALL THE FRONT TRUCK

STEP 8

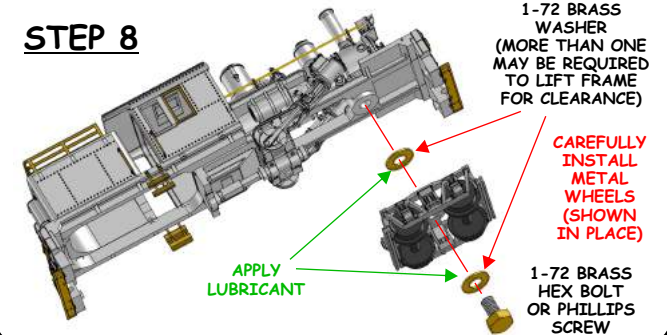

STEP 9

